

900RE SERIES LOW PROFILE HEAVY-DUTY GAS GRIDDLE



SPECIFICATIONS:

Low profile heavy duty gas griddle, Vulcan-Hart Model No. _____. Stainless steel front, sides and 4" front top ledge. Fully welded stainless and aluminized steel body frame. 11" low profile cooking height on 4" legs. 1" thick polished steel griddle plate welded to stainless steel back and tapered side splashers. One 30,000 BTU/hr. "U" shaped aluminized steel burner and 120 volt snap action thermostat for each 12" of griddle width. Temperature adjusts from 150° to 450°F. Electronic ignition. 3½" wide stainless steel front grease trough. Large capacity 6⅞" wide x 30" deep x 2½" high stainless steel grease drawer. ¾" rear gas connection and gas pressure regulator. 120 volt control circuit, 6' cord with 3 prong plug.

Exterior dimensions: _____" w x 33" d x 15½" h on 4" legs.

CSA design certified. NSF listed.

SPECIFY TYPE OF GAS AND FINISH WHEN ORDERING.

SPECIFY ALTITUDE WHEN ABOVE 2,000 FT.

- 924RE** 24" w x 24" d griddle plate
- 936RE** 36" w x 24" d griddle plate
- 948RE** 48" w x 24" d griddle plate
- 960RE** 60" w x 24" d griddle plate
- 972RE** 72" w x 24" d griddle plate

STANDARD FEATURES

- Stainless steel front, sides and 4" front top ledge.
- Fully welded stainless and aluminized steel body frame.
- 11" low profile cooking height on 4" adjustable legs.
- 1" thick polished steel griddle plate welded to stainless steel back and tapered side splashers.
- One 30,000 BTU/hr. "U" shaped aluminized steel burner and 120 volt snap action thermostat for each 12" of griddle width. Temperature adjusts from 150° to 450°F.
- Electronic ignition.
- 3½" wide stainless steel front grease trough.
- Large capacity 6⅞" wide x 30" deep x 2½" high stainless steel grease drawer.
- ¾" rear gas connection and gas pressure regulator. 120 volt control circuit, 6' cord with 3 prong plug.
- One year limited parts and labor warranty.

OPTIONS

- Leg Lengths: 4", 5⅝", 8", 10", 11¾".
- Chrome-plated cooking surface.
- Rear grease trough.
- Full or partially grooved griddle plates.
- Stainless steel stand with marine edges and casters.
- Towel bar.
- Full width cutting board.



900RE SERIES

LOW PROFILE HEAVY-DUTY GAS GRIDDLE

IMPORTANT

1. A gas pressure regulator supplied with the unit must be installed:
 Natural Gas 5.0" (127 mm) W.C.
 Propane Gas 10.0" (254 mm) W.C.
2. All models require a 6" (152 mm) clearance at both sides and rear adjacent to combustible constructions and 0" from non-combustible constructions. All models require a 4" (102 mm) bottom clearance and must be installed with minimum 4" legs.
3. These units are manufactured for installation in accordance with ANSI/NFPA-70, National Electrical code.
 An adequate ventilation system is required for Commercial Cooking Equipment (NFPA No. 96). Information may be

obtained by writing to the National Fire Protection Association, Batterymarch Park, Quincy, MA 02269.

4. These units are manufactured for installation in accordance with National Fuel Gas Code, ANSI-Z223.1/NFPA #54 (latest edition). This shall include but not be limited to: NFPA #54 Section 10.3.5.2 for Venting. Copies may be obtained from The American Gas Association Accredited Standards Committee Z223, @ 400 N. Capital St. NW, Washington, DC 20001 or the Secretary Standards Council, NFPA, 1 Batterymarch Park Quincy, MA 02169-7471.
5. This appliance is manufactured for commercial installation only and is not intended for home use.

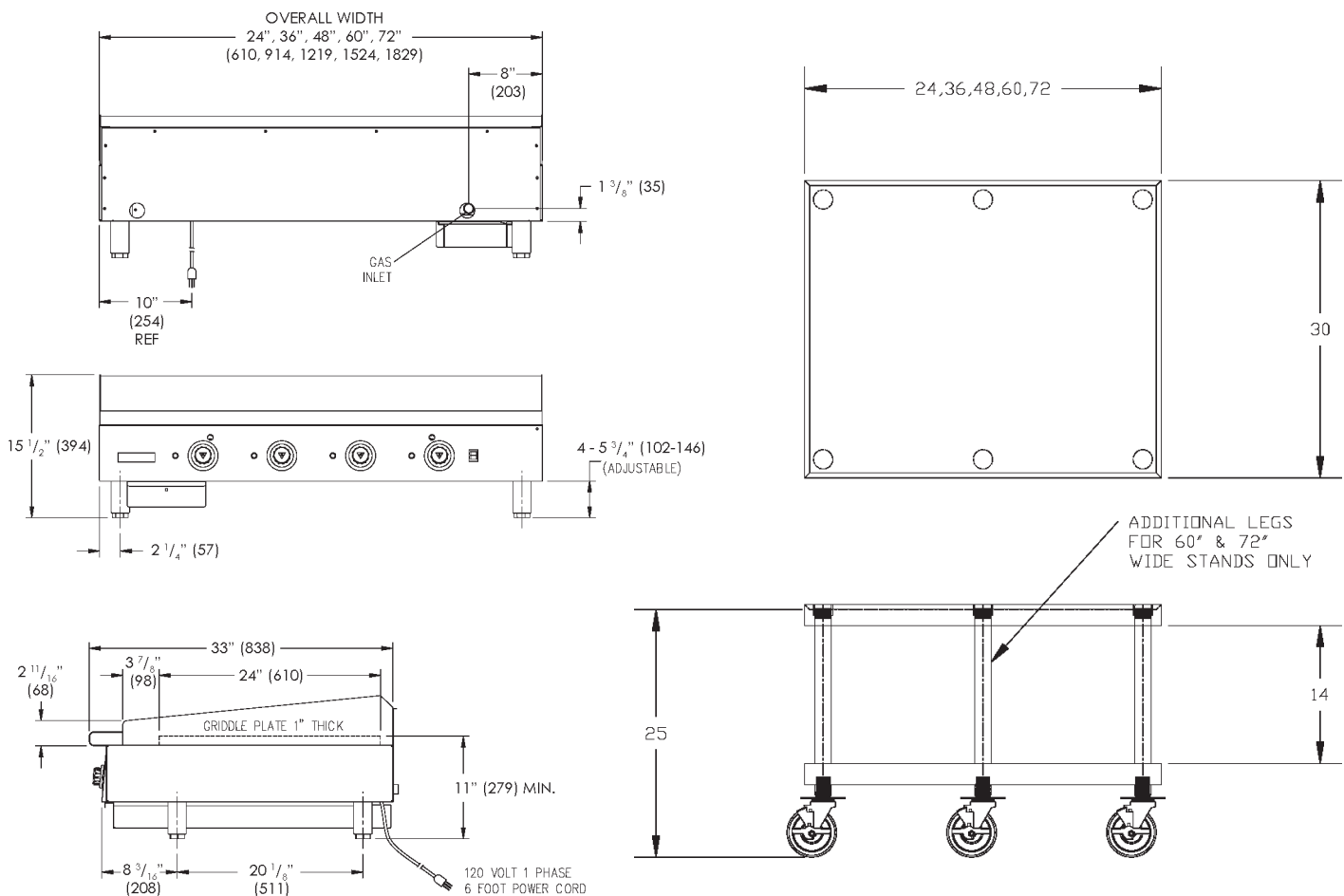

MODEL	WIDTH	DEPTH	OVERALL HEIGHT*	WORKING HEIGHT*	NO. OF BURNERS	TOTAL BTU/HR.	NO. OF DRAWERS	APPROX. SHP.WT.
924RE	24"	33"	15 1/2"	11"	2	60,000	1	285 lbs./129 kg
936RE	36"	33"	15 1/2"	11"	3	90,000	1	400 lbs./181 kg
948RE	48"	33"	15 1/2"	11"	4	120,000	1	480 lbs./218 kg
960RE	60"	33"	15 1/2"	11"	5	150,000	1	650 lbs./295 kg
972RE	72"	33"	15 1/2"	11"	6	180,000	2	790 lbs./358 kg

*These are nominal dimensions and can vary by +1.75" with adjustable legs.

NOTE: In line with its policy to continually improve its products, Vulcan-Hart Company reserves the right to change materials and specifications without notice.

VULCAN-HART COMPANY, P.O. BOX 696, LOUISVILLE, KY 40201, TEL. 1-800-814-2028
 502-778-2791 QUOTE & ORDER FAX: 1-800-444-0602